

hebö Luftschmiedehammer

hebö power hammer

Kreatives Schmieden für Profis
Creative forging for professionals



hebö Luftschmiedehammer

LH 34 / LH 40 / LH50 / LH 60

hebö power hammer



Der hebö Luftschmiedehammer eignet sich für einfache bis schwere Schmiedearbeiten, Feinschmiedearbeiten und das Ausschmieden von Enden. So können Sie vor allem Zier- und Schmiedestäbe, aber auch Dekorelemente wie z.B. Zierblätter, Türbeschläge oder Zierspitzen gestalten.

Alle hebö Luftschmiedehämmer verfügen über Geräuschdämpfung, einen vibrationsarmen Lauf und lassen sich einfach bedienen. Die Schlagstärke von bis zu 60 kg (bei LH 60) ist durch den ergonomischen Fußbedienungshebel vollständig regulierbar. Auf Wunsch liefern wir Ihr Modell inklusive Fundament. Zur Verwirklichung kreativer Ideen können Sie bei hebö auf eine reichhaltige Auswahl hochwertiger Schmiedegesenke zum Aufrüsten Ihres hebö Luftschmiedehammers zurückgreifen.

The hebö air power hammer is ideal for easy up to difficult forging operations and end forging. Above all you are able to create mainly ornamental bars and decoration elements as well, like leafs, door fittings, spear heads or forged bars.

All hebö air power hammers are provided with noise-reduction, a low vibration-operation and are easy to work with.

Impact strength of up to 60 kg (at LH60) is fully adjustable by the ergonomic foot pedal. Also no external air supply is necessary. On request we deliver a foundation together with your power hammer. Hebö supplies a wide range of high-quality forging dies for the realization of your creative ideas.



Automatische Schmierung für dauerhaften Betrieb

Automatic lubrication for continuous operation

Technische Daten

Technical data

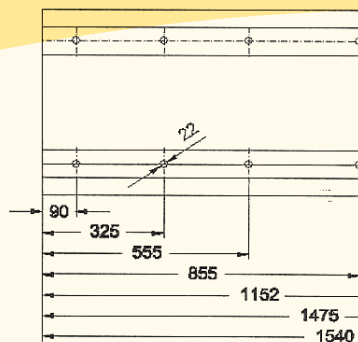
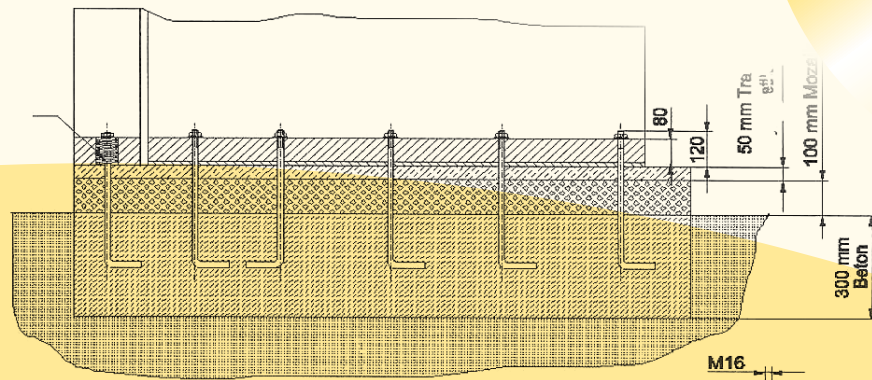

Jede Maschine wird mit detailliertem Fundamentplan ausgeliefert

Every machine comes with a detailed foundation blueprint

Mitgeliefertes Grundzubehör:

- 1 Satz Flachgesenke
ArtNr. 1101 / 2101



Basic equipment supplied:

- 1 set of flat forging dies
ArtNr. 1101 / 2101

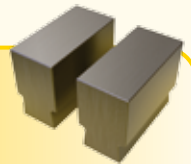

	LH 34	LH 40	LH 50	LH 60
Bärgewicht <i>Nominal Dropping Weight</i>	ca. 34 kg	ca. 40 kg	ca. 50 kg	ca. 60 kg
Schlagzahl pro min. <i>Number of hits per min.</i>	220	220	220	220
Motorleistung <i>Motor power</i>	5.5 kw	5.5 kw	7.5 kw	7.5 kw
Bärhub <i>Hit Stroke</i>	200 mm	200 mm	230 mm	230 mm
Netto Gewicht <i>Net Weight</i>	540 kg	640 kg	1150 kg	1400 kg
Bautiefe /Breite <i>Construction Depth/ Width</i>	1300 x 710 mm	1270 x 780 mm	1600 x 900 mm	1600 x 900 mm
Bedienung <i>Control</i>	_____		Fußpedal <i>Foot pedal</i>	_____

hebö - Luftschmiedehammer-Gesenke

hebö power hammer forging dies



1101 (LH 34 / 40) 120 x 60 mm
2101 (LH 50 / 60) 120 x 60 mm



1102 (LH 34 / 40) 130 x 80 mm
2102 (LH 50 / 60) 160 x 80 mm

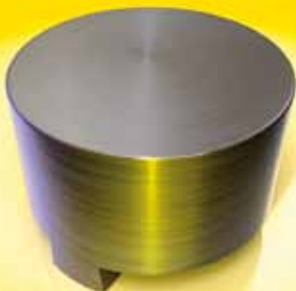

1103 (LH 34 / 40) ϕ 175 mm
2103 (LH 50 / 60) ϕ 200 mm



1104 (LH 34 / 40) 100 x 60 mm
2104 (LH 50 / 60) 100 x 60 mm

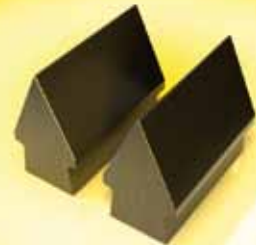

1105 (LH 34 / 40) 120 x 60 mm
2105 (LH 50 / 60) 120 x 60 mm



1106 (LH 34 / 40) 100 x 60 mm
2106 (LH 50 / 60) 120 x 60 mm



1107 (LH 34 / 40) 120 x 60 mm
2107 (LH 50 / 60) 120 x 60 mm



1108 (LH 34 / 40) 130 x 100 mm
2108 (LH 50 / 60) 130 x 100 mm



1109 (LH 34 / 40) 120 x 60 mm
2109 (LH 50 / 60) 120 x 60 mm



1110 (LH 34 / 40) 120 x 60 mm
2110 (LH 50 / 60) 120 x 60 mm

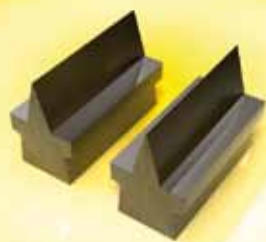

1111 (LH 34 / 40) 100 mm
2111 (LH 50 / 60) 110 mm

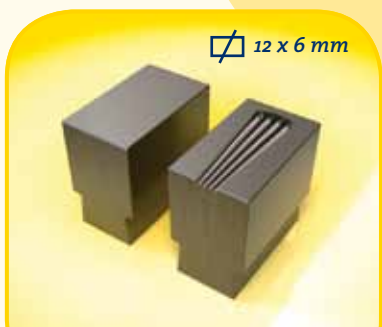

1112 (LH 34 / 40) 100 x 60 mm
2112 (LH 50 / 60) 100 x 60 mm

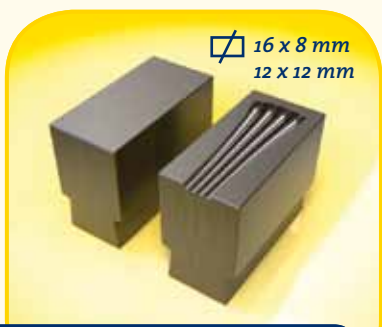

1113 (LH 34 / 40) 120 x 60 mm
2113 (LH 50 / 60) 120 x 60 mm

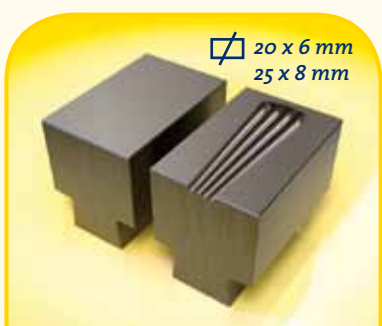

1114 (LH 34 / 40) 120 x 80 mm
2114 (LH 50 / 60) 120 x 80 mm

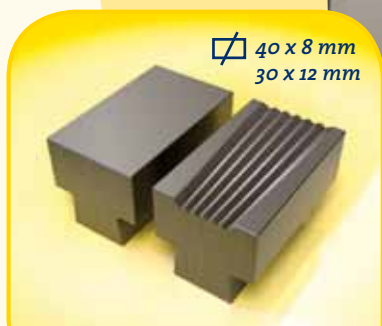

1115 (LH 34 / 40) 130 x 80 mm
2115 (LH 50 / 60) 130 x 80 mm

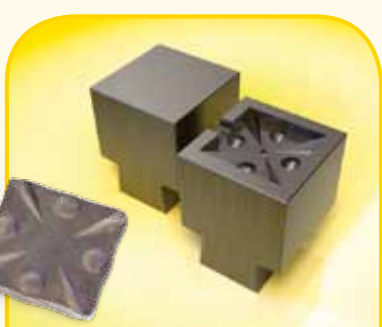

1116 (LH 34 / 40) 80 x 80 mm
2116 (LH 50 / 60) 80 x 80 mm

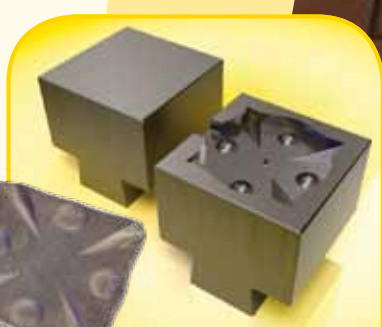

2117 (LH 50 / 60) 100 x 100 mm



hebö - Luftschmiedehammer-Gesenke

hebö power hammer forging dies



2118 (LH 50 / 60) 160 x 80 mm

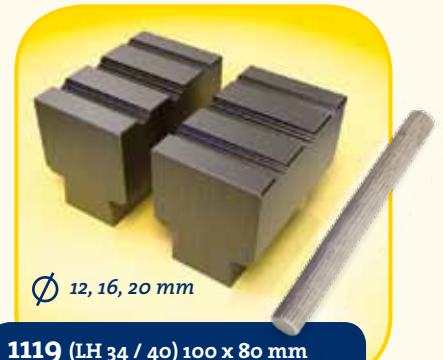

Ø 12, 16, 20 mm

1119 (LH 34 / 40) 100 x 80 mm
2119 (LH 50 / 60) 130 x 80 mm



Ø 12-14 mm

1124 (LH 34 / 40) 120 x 100 mm
2124 (LH 50 / 60) 120 x 100 mm



Ø 12-14 mm

1125 (LH 34 / 40) 120 x 70 mm
2125 (LH 50 / 60) 120 x 70 mm



12 x 6 mm

1127 (LH 34 / 40) 135 x 60 mm
2127 (LH 50 / 60) 135 x 60 mm

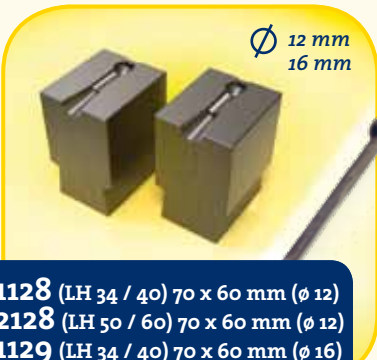

Ø 12 mm
16 mm

1128 (LH 34 / 40) 70 x 60 mm (Ø 12)
2128 (LH 50 / 60) 70 x 60 mm (Ø 12)
1129 (LH 34 / 40) 70 x 60 mm (Ø 16)
2129 (LH 50 / 60) 70 x 60 mm (Ø 16)

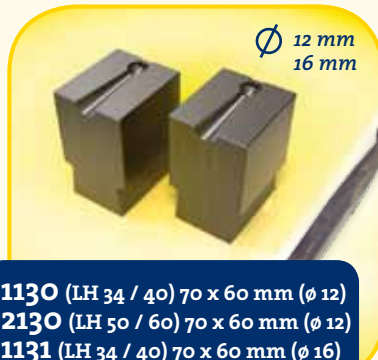

Ø 12 mm
16 mm

1130 (LH 34 / 40) 70 x 60 mm (Ø 12)
2130 (LH 50 / 60) 70 x 60 mm (Ø 12)
1131 (LH 34 / 40) 70 x 60 mm (Ø 16)
2131 (LH 50 / 60) 70 x 60 mm (Ø 16)



Ø 12 mm

1132 (LH 34 / 40) 70 x 60 mm
2132 (LH 50 / 60) 70 x 60 mm



1133 (LH 34 / 40) 120 x 60 mm
2133 (LH 50 / 60) 120 x 60 mm



1134 (LH 34 / 40) 100 x 60 mm
2134 (LH 50 / 60) 100 x 60 mm



1135 (LH 34 / 40) 130 x 60 mm
2135 (LH 50 / 60) 130 x 60 mm



2136 (LH 50 / 60) 160 x 80 mm



2137 (LH 50 / 60) 160 x 80 mm



1138 (LH 34 / 40) 100 x 60 mm
2138 (LH 50 / 60) 100 x 60 mm



1139 (LH 34 / 40) 100 x 60 mm
2139 (LH 50 / 60) 100 x 60 mm



2140 (LH 50 / 60) 160 x 80 mm



1141 (LH 34 / 40) 140 x 60 mm
2141 (LH 50 / 60) 150 x 60 mm



2142 (LH 50 / 60) 180 x 80 mm



1143 (LH 34 / 40) 100 x 60 mm
2143 (LH 50 / 60) 100 x 60 mm



DISTRIBUTEUR EXCLUSIF EN FRANCE, ALGERIE, MAROC ET TUNISIE POUR :



6 Allée des Carrières
Z.A.E Des Portes de la Forêt
F-77090 COLLEGIEN

Tél. : +33 (0) 1 64 30 92 47
Fax : +33 (0) 1 64 30 81 92
Email : info@eckotech.fr
Site internet : www.eckotech.fr

SARL au capital de 100 000 €
SIRET : 350 241 378 00016
Code APE : 4662Z - N° EORI : FR35024137800016
N° d'identification européenne : FR 67 350 241 378